

Werkzeugkatalog

tool catalogue

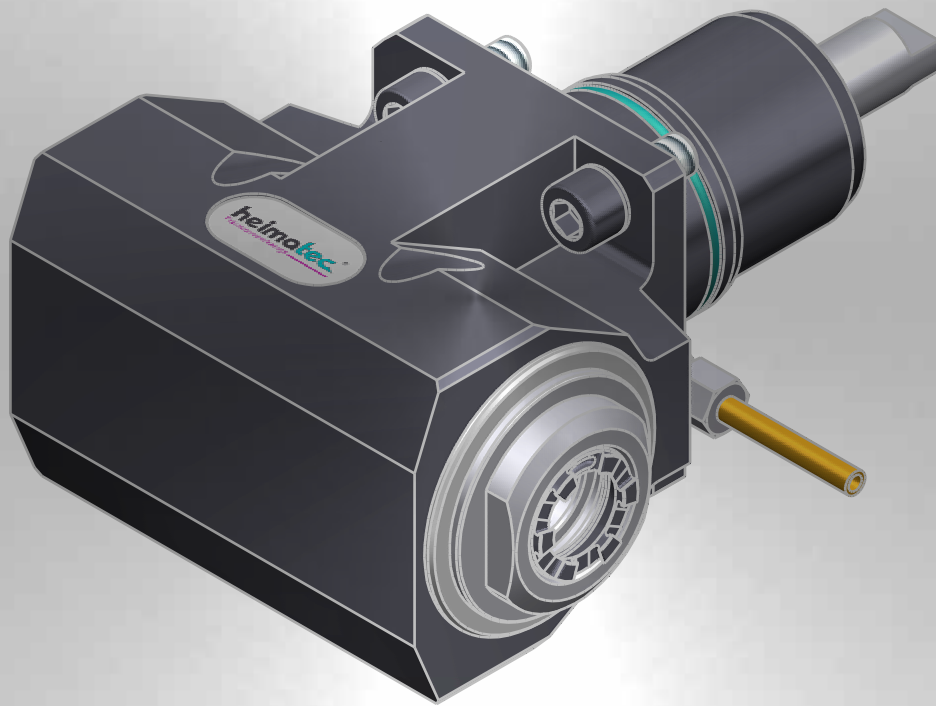

Nakamura

AS 200

80er Revolver (55) / 80 turret (55)

12 Stationen / 12 stations



Hinweis zu den AGBs:

Diese finden Sie in unserem Internetauftritt unter

www.heimatec.de

Home/Impressum/AGB

Terms and conditions:

You will find them on our website

www.heimatec.com

Home/Imprint/Terms and Conditions

Das Katalog-Werk einschließlich aller seiner Teile ist urheberrechtlich geschützt. Jede Verwertung außerhalb der engen Grenzen des Urheberrechtsgesetzes ist ohne Zustimmung der Rechteeinhaber unzulässig und strafbar. Das gilt insbesondere für Vervielfältigungen, Übersetzungen, Mikroverfilmungen und die Einspeicherung und Verarbeitung in elektronischen Systemen.

heimatec® GmbH behält sich Änderungen technischer Art jederzeit ohne Vorankündigung vor. Dies gilt insbesondere bei Anpassungen an neue oder geänderte internationale Normen oder bei Weiterentwicklungen unserer Produkte oder Herstellungsprozesse.

This catalogue, including all its parts, is protected by copyright. Each use outside the restricted limitations of the Copyright Act is inadmissible and liable to prosecution without the consent of heimatec. This is particularly valid for duplication, translation, microfilming and feeding and processing in electronic systems.

heimatec® GmbH reserves the right of technical changes everytime without advance notice, which is particularly valid for adaptations to new or changed international standards, or to developments of our products or manufacturing processes.

angetriebene Werkzeuge
driven tools



Axial-Bohr- und Fräskopf
axial drilling and milling head

$n_{max} = 6000 \text{ min}^{-1}$

8 010 55 033	ER 25 AX u-tec	EK	1:1
8 010 55 034	ER 25 AX u-tec	IK 25 bar	1:1
8 010 55 035	ER 25 AX u-tec	IK 70 bar	1:1
8 010 56 063	ER 32 AX u-tec	EK	1:1
8 010 56 064	ER 32 AX u-tec	IK 25 bar	1:1
8 010 56 065	ER 32 AX u-tec	IK 70 bar	1:1



Axial-Bohr- und Fräskopf *
axial drilling and milling head

$n_{max} = 6000 \text{ min}^{-1}$

8 010 56 059	easy quick HT 4	EK	1:1
8 010 56 066	easy quick HT 4	IK 25 bar	1:1
8 010 56 067	easy quick HT 4	IK 70 bar	1:1



Axial-Bohr- und Fräskopf **kurze Ausführung**
axial drilling and milling head **short version**

$n_{max} = 6000 \text{ min}^{-1}$

8 010 56 032	easy quick HT 4	EK	1:1
8 010 56 031	easy quick HT 4	IK 25 bar	1:1



Axial-Bohr- und Fräskopf *
axial drilling and milling head

$n_{max} = 24000 \text{ min}^{-1}$

8 013 54 005	ER 16 AX u-tec	EK	1:4
8 013 54 007	ER 16 AX u-tec	IK 70 bar	1:4



Axial-Fräskopf
axial milling head

$n_{max} = 6000 \text{ min}^{-1}$

8 011 54 012	Kombidorn/universal arbor 16	EK	1:1
8 011 55 015	Kombidorn/universal arbor 22	EK	1:1
8 011 54 006	Kombidorn/universal arbor 3/4"	EK	1:1
8 011 54 009	Kombidorn/universal arbor 1/2"	EK	1:1

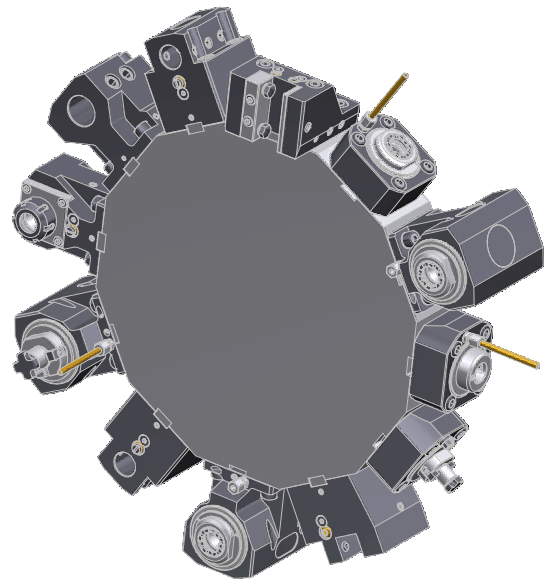

* Parameteränderung der Maschine erforderlich
parameter change is required



Axial-Bohr- und Fräskopf *
axial drilling and milling head

Achsversatz / offset A=42

8 019 55 018	ER 25 AX u-tec	EK	1:1
8 019 55 023	ER 25 AX u-tec	IK 140 bar	1:1
$n_{max} = 6000 \text{ min}^{-1}$			
8 019 55 024	ER 25 AX u-tec	EK	1:2
8 019 55 025	ER 25 AX u-tec	IK 140 bar	1:2
$n_{max} = 12000 \text{ min}^{-1}$			
8 019 55 026	ER 25 AX u-tec	EK	1:3
8 019 55 027	ER 25 AX u-tec	IK 140 bar	1:3
$n_{max} = 18000 \text{ min}^{-1}$			
8 019 55 028	ER 25 AX u-tec	EK	2:1
8 019 55 029	ER 25 AX u-tec	IK 140 bar	2:1
$n_{max} = 3000 \text{ min}^{-1}$			



Winkel-Bohr- und Fräskopf
radial drilling and milling head

Mittenmaß / center distance H=55

$n_{max} = 6000 \text{ min}^{-1}$

8 030 55 007	ER 25	EK	1:1
8 030 55 004	ER 25	IK 140 bar	1:1
8 030 55 131	ER 25 AX u-tec	EK	1:1
8 030 55 154	ER 25 AX u-tec	IK 140 bar	1:1

► Weitere Ausführungen auf Anfrage
further versions on request

► Zubehör ZB...*
accessories ZB...*

► easy-quick

► u-tec



**Winkel-Bohr- und Fräskopf *
radial drilling and milling head**

Mittenmaß / center distance H=65
n_{max} = 6000 min⁻¹

8 030 55 092	ER 25 AX u-tec	EK	1:1
8 030 55 091	ER 25 AX u-tec	IK 140 bar	1:1
8 030 56 095	ER 32 AX u-tec	EK	1:1
8 030 56 096	ER 32 AX u-tec	IK 140 bar	1:1
8 030 56 072	easy quick HT 4	EK	1:1
8 030 56 075	easy quick HT 4	IK 140 bar	1:1



**Winkel-Bohr- und Fräskopf *
radial drilling and milling head**

Mittenmaß / center distance H=65
n_{max} = 3000 min⁻¹

8 030 55 063	ER 25 AX u-tec	EK	2:1
8 030 55 064	ER 25 AX u-tec	IK 140 bar	2:1
8 030 56 070	ER 32 AX u-tec	EK	2:1
8 030 56 090	ER 32 AX u-tec	IK 140 bar	2:1
8 030 56 073	easy quick HT 4	EK	2:1
8 030 56 059	easy quick HT 4	IK 140 bar	2:1



**Winkel-Bohr- und Fräskopf *
radial drilling and milling head**

Mittenmaß / center distance H=77
n_{max} = 12000 min⁻¹

8 030 55 122	ER 25 AX u-tec	EK	1:2
8 030 55 123	ER 25 AX u-tec	IK 140 bar	1:2
8 030 56 126	easy quick HT 4	EK	1:2
8 030 56 125	easy quick HT 4	IK 140 bar	1:2



**Winkel-Bohr- und Fräskopf *
radial drilling and milling head**

Mittenmaß / center distance H=77
n_{max} = 18000 min⁻¹

8 030 55 140	ER 25 AX u-tec	EK	1:3
8 030 55 139	ER 25 AX u-tec	IK 140 bar	1:3
8 030 56 124	easy quick HT 4	EK	1:3
8 030 56 121	easy quick HT 4	IK 140 bar	1:3

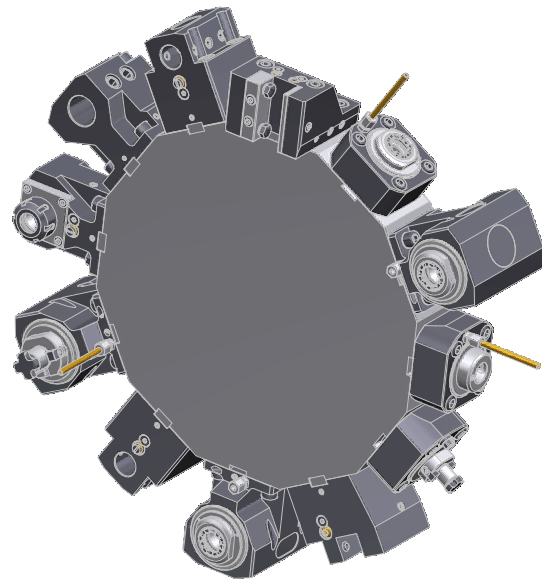

* Parameteränderung der Maschine erforderlich
parameter change is required



**Winkel-Bohr- und Fräskopf *
radial drilling and milling head**

Mittenmaß / center distance H=65
n_{max} = 24000 min⁻¹

8 030 54 042	ER 16 AX u-tec	EK	1:4
8 030 54 050	ER 16 AX u-tec	IK 140 bar	1:4



**Winkel-Fräskopf *
radial milling head**

Mittenmaß / center distance H=65
n_{max} = 6000 min⁻¹

8 031 54 014	Kombidorn/universal arbor 16	EK 1:1
8 031 55 016	Kombidorn/universal arbor 22	EK 1:1
8 031 56 012	Kombidorn/universal arbor 27	EK 1:1
8 031 54 016	Kombidorn/universal arbor 3/4"	EK 1:1
8 031 55 019	Kombidorn/universal arbor 1"	EK 1:1



**Schwenkkopf *
universal head**

Mittenmaß / center distance H=57
n_{max} = 6000 min⁻¹

8 040 53 000	ER 11 A	EK	1:1
8 040 54 002	ER 16	EK	1:1

▶ Weitere Ausführungen auf Anfrage
further versions on request

▶ Zubehör ZB...*
accessories ZB...*

▶ easy-quick

▶ u-tec



**Schwenkkopf *
universal head**

Mittenmaß / center distance H=69
Achsversatz / offset A=60

8 043 54 000	ER 16 AX u-tec	EK	1:1
8 043 54 001	ER 16 AX u-tec	IK 140 bar	1:1
<i>n_{max} = 6000 min⁻¹</i>			
8 043 54 002	ER 16 AX u-tec	EK	1:2
8 043 54 003	ER 16 AX u-tec	IK 140 bar	1:2
<i>n_{max} = 12000 min⁻¹</i>			



**Winkel-Scheibenfräserkopf *
radial disk mill head**

Mittenmaß / center distance H=76
auf 0° absteckbar / 0° can be pinned
n_{max} = 3000 min⁻¹
kein Kühlmittel / no coolant

8 037 53 001	∅ 13	2:1	±10° drehbar ±10° turnable
8 037 54 015	∅ 5/8"	2:1	
8 037 54 016	∅ 1/2"	2:1	

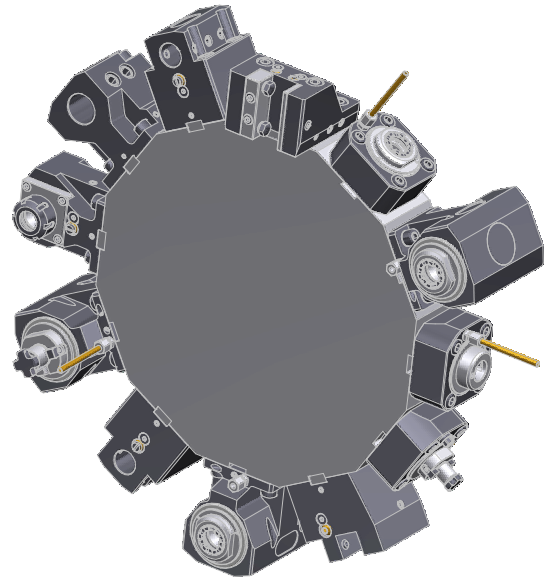

* Parameteränderung der Maschine erforderlich
parameter change is required



**Axial-Mehrspindel Werkzeuge *
axial multi spindle tools**

**2-spindlig
2-spindles**

Achsversatz / offset A=56
n_{max} = 6000 min⁻¹

8 050 54 001	ER 16 AX u-tec	EK	1:1
8 050 54 002	ER 16 AX u-tec	IK 25 bar	1:1



**Axial-Mehrspindel Werkzeuge *
axial multi spindle tools**

**3-spindlig
3-spindles**

Achsversatz / offset A=0/56
n_{max} = 6000 min⁻¹

8 050 54 003	ER 16 AX u-tec	EK	1:1
--------------	----------------	----	-----



**Winkel-Mehrspindel Werkzeuge *
angle multi spindle tools**

**2-spindlig
2-spindles**

Mittenmaß / center distance H=65
n_{max} = 6000 min⁻¹

8 053 54 000	ER 16 AX u-tec	EK	1:1
8 053 54 001	ER 16 AX u-tec	IK 25 bar	1:1

► Weitere Ausführungen auf Anfrage
further versions on request

► Zubehör ZB...*
accessories ZB...*

► easy-quick

► u-tec

feste Werkzeuge
static tool holders



Kombi-Drehstahlhalter universal turning holder			
8 224 15 002	Vierkant/square 25/20		EK
8 224 15 012	Vierkant/square 1"		EK



Abstechhalter / Drehhalter cut-off holder / turning holder			
8 224 11 005	Vierkant/square 20	(1)	EK
8 224 11 018	Vierkant/square 3/4"	(1)	EK
8 225 11 005	Vierkant/square 20	(2)	EK
8 225 11 012	Vierkant/square 3/4"	(2)	EK
8 224 11 003	Vierkant/square 20	(3)	EK
8 224 11 016	Vierkant/square 3/4"	(3)	EK
8 225 11 002	Vierkant/square 20	(4)	EK
8 225 11 009	Vierkant/square 3/4"	(4)	EK

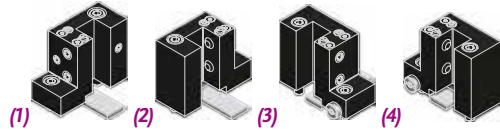

Abstechhalter cut-off holder			
8 224 13 007	SH 32	(1)	EK
8 224 13 004	SH 32	(2)	EK

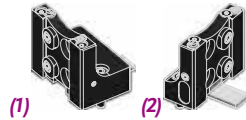

Kombi-Plandrehhalter combi facing holder			
8 244 11 002	Vierkant/square 20		EK



Plandrehhalter facing holder			
8 244 12 002	Vierkant/square 25		EK
8 244 12 005	Vierkant/square 1"		EK

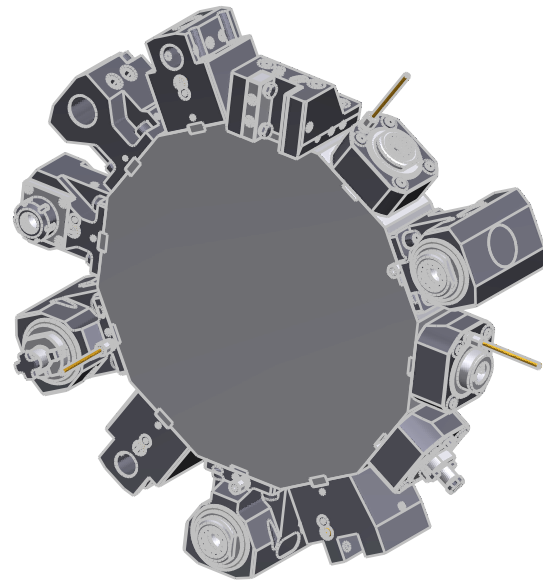

* Parameteränderung der Maschine erforderlich
parameter change is required



Bohrstangenhalter boring bar holder			
	Mittenmaß / center distance	H=55	
8 240 16 002	ø20		IK/EK
8 240 17 004	ø25		IK/EK
8 240 18 011	ø32		IK/EK
8 240 17 061	ø1"		IK/EK



Bohrstangenhalter *			
boring bar holder			
	Mittenmaß / center distance	H=75	
8 240 17 005	ø25		IK/EK
8 240 18 010	ø32		IK/EK
8 240 19 009	ø40		IK/EK
8 240 17 011	ø1"		IK/EK
8 240 18 033	ø1 1/4"		IK/EK
8 240 18 037	ø1 1/2"		IK/EK

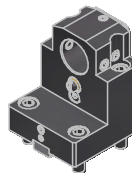

Bohrstangenhalter *			
boring bar holder			
	Mittenmaß / center distance	H=75	
	zurückgesetzt / offset		
8 240 18 012	ø32		IK/EK
8 240 19 007	ø40		IK/EK
8 240 17 049	ø1"		IK/EK

▶ Weitere Ausführungen auf Anfrage
further versions on request

▶ Zubehör ZB...*
accessories ZB...*

▶ easy-quick

▶ u-tec



Doppel-Bohrstangenhalter
double boring bar holder

Mittenmaß / center distance H=39/75

8 253 17 013	ø25	IK/EK
8 253 17 066	ø1"	IK/EK

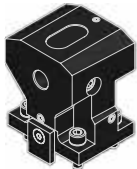

Halter für Wendepplattenbohrer *
insert drill holder

Mittenmaß / center distance H=75

8 240 15 007	ø16	IK
8 240 16 009	ø20	IK
8 240 17 023	ø25	IK
8 240 18 021	ø32	IK



Aufnahmehalter *
tool holder

Mittenmaß / center distance H=75

8 240 15 006	ER 25	IK/EK
8 240 16 008	ER 32	IK/EK
8 240 16 004	easy quick HT 4	IK/EK

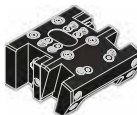

Kombi-Mehrfachdrehalter
combi multiple holder

für ½ Stationen-Takt / for ½ station indexing

8 251 14 004	6x Vierkant/square 20	EK
8 251 14 027	6x Vierkant/square 3/4"	EK



Mehrfach-Bohrstangenhalter
multiple boring bar holder

für ½ Stationen-Takt / for ½ station indexing
 Mittenmaß / center distance H=75

8 253 17 064	2x ø25	IK/EK
8 253 17 067	2x ø1"	IK/EK

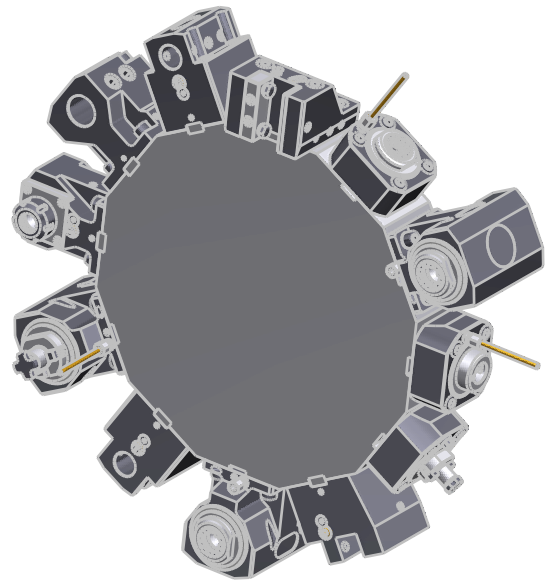

* Parameteränderung der Maschine erforderlich
 parameter change is required

Hauptsitz/headquarters

heimatec® GmbH
Präzisionswerkzeuge
Carl-Benz-Straße 4
D- 77871 Renchen
Postfach 11 36
D- 77867 Renchen
Tel.: +49 (78 43) 94 66 0
Fax: +49 (78 43) 94 66 66
www.heimatec.de
info@heimatec.de

heimatec® Inc.
16 E. Piper Lane Suite 121
USA- 60070 Prospect Heights IL
Tel.: +1 (847) 749 0633
Fax: +1 (847) 749 2445
www.heimatecinc.com
info@heimatecinc.com

heimatec® - Ost, JSC
ul. Kozjubinskogo 4 office 209
RUS- 121351 Moskau
Tel.: +7 (495) 648 69 19
Fax: +7 (495) 648 69 19
www.heimatec-ost.ru
sales@heimatec-ost.ru

